

# IR Quattro HD DCS

## Digital Control Solution - Presence Detector



The IR Quattro HD DCS is a digital, high definition, passive infrared presence detector setting a new standard in lighting control with minimal movement required for human presence detection. It features four pyroelectric detectors with a high performance lens system that creates a new global standard in detection with 4,800 switching zones. Included light level feature provides the option to dim and turn lights off when sufficient daylight is present for additional energy savings.

The innovative mechanical reach setting allows a precise method of controlling lighting zones by means of optimizing the detection reach without compromising sensitivity. The convenient polarity insensitive data line bus enables multiple sensors, photo sensors and switches to link together providing convenient code compliant solutions. Mounting options provide for 4" square box, 4" octagon box, round 3.0 mud-ring or directly to the ceiling with quick mount spring tabs.

The Digital Controls Solution (DCS) group of sensors are available in multiple technologies for the control of heating, ventilation and air conditioning as well as lighting. Time saving wireless commissioning is accomplished via Bluetooth connection from a Smart Phone or Tablet to a DCS Controller, which communicates to the sensor by the 2 wire bus.

### Applications

The typical application is for offices, conference rooms, classrooms and other indoor public building spaces.

Project Name:  
Location:

69340



65330



69196



### IR Quattro HD DCS Specifications

Item No.	69340 IR Quattro HD DCS
Accessories	65330 WGC wire guard cage 69196 DCS Controller
Voltage	12 - 22.5 VAC (10 mA)
Device Equivalent	4
Sensing Technology	Passive Infrared (PIR)
Time Delay Setting	Test Mode 8 sec. Normal Mode 30 sec. - 30 min. IQ mode (automatic adjustment to the usage profile)
Light Level Setting	10 - 1000 lux / 1 - 92 fc
Environment	IP20 rated, 0°C to + 40°C, 32°F to +104°F
Installation Height	2.5 - 10 m / 8 - 32 ft
Coverage at 9 ft	360° square mechanically scalable detection zones presence: max. 7.9 x 7.9 m (62.41 sq.m.) max. 25.5 x 25.5 ft (650.25 sq.ft.) radially: max. 7.9 x 7.9 m (62.41 sq.m.) max. 25.5 x 25.5 ft (650.25 sq.ft.) tangentially: max. 20 x 20 m (400.0 sq.m.) max. 65.5 x 65.5 ft (4,290.25 sq.ft.)
Sensors	4 infrared pyroelectric detectors
Lens Design	13 detection levels, 4800 switching zones
Dimensions	4.72 x 4.72 x 2.83 in, 120 x 120 x 73 mm (LxWxD)
Warranty	5 years
Certifications	C-UL-US Listed, RoHS compliant, UL 2043 Plenum Rated, CA Energy Code compliant

### Key Features:

- Low voltage (12-23 V) digital sensor for use with a DCS Controller
- Extremely High Definition PIR Presence Detection
- Mechanical reach setting
- Square coverage pattern with 4800 switching zones
- Wireless configuration via Steinel App
- Integrated photo cell for daylight harvesting
- Mounts to a 4" square box, 4" octagon box, round 3.0 mud-ring or directly to the ceiling with quick mount spring tabs
- Polarity insensitive 2 wire bus
- IQ Mode dynamically adjusts the 'ON' time delay by learning individual room occupancy

HD

4800 PIR Detection Zones



26 x 26 Ft Presence  
65 x 65 Ft Tangential



1 - 100 fc



30 sec - 30 min

# IR Quattro HD DCS

Digital Control Solution - Presence Detector



## Wiring

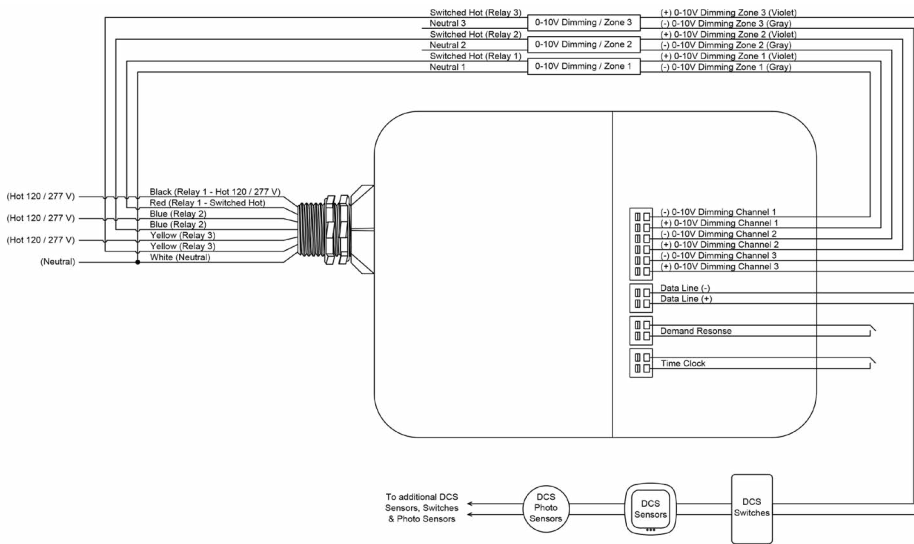

## Settings

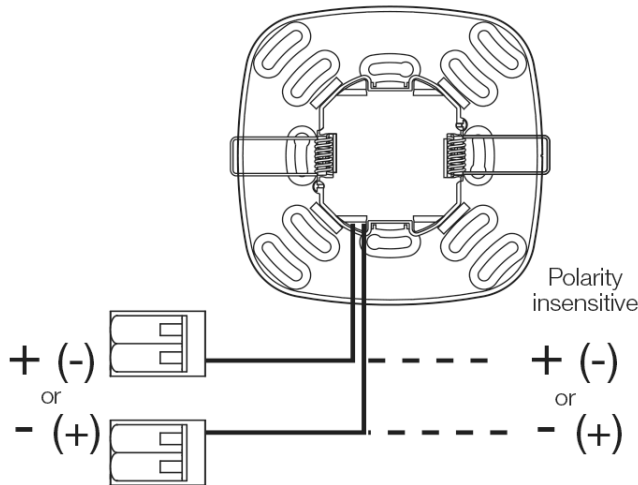

## Mounting

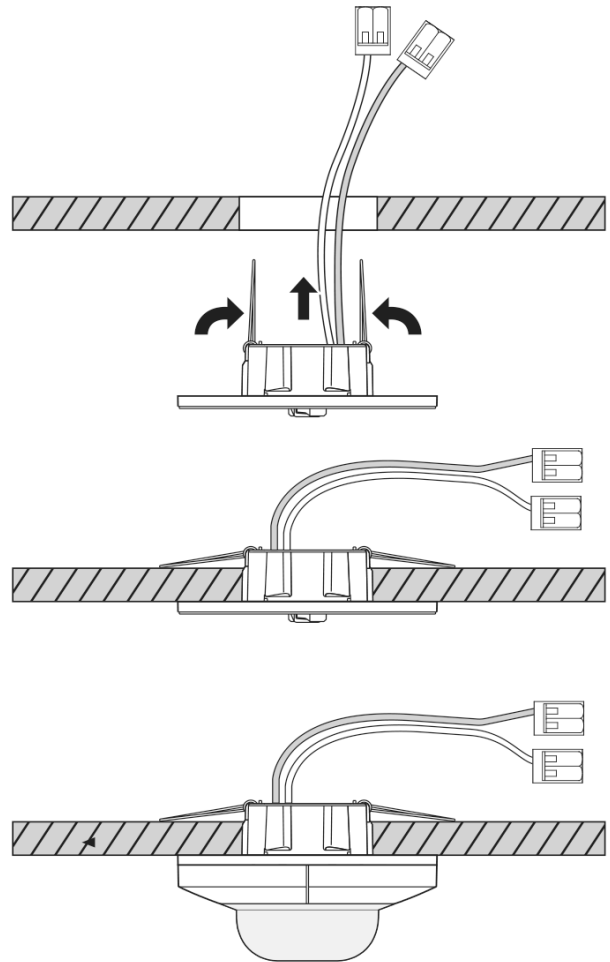

## Coverage

